

TYPICAL GATE WELL PLAN

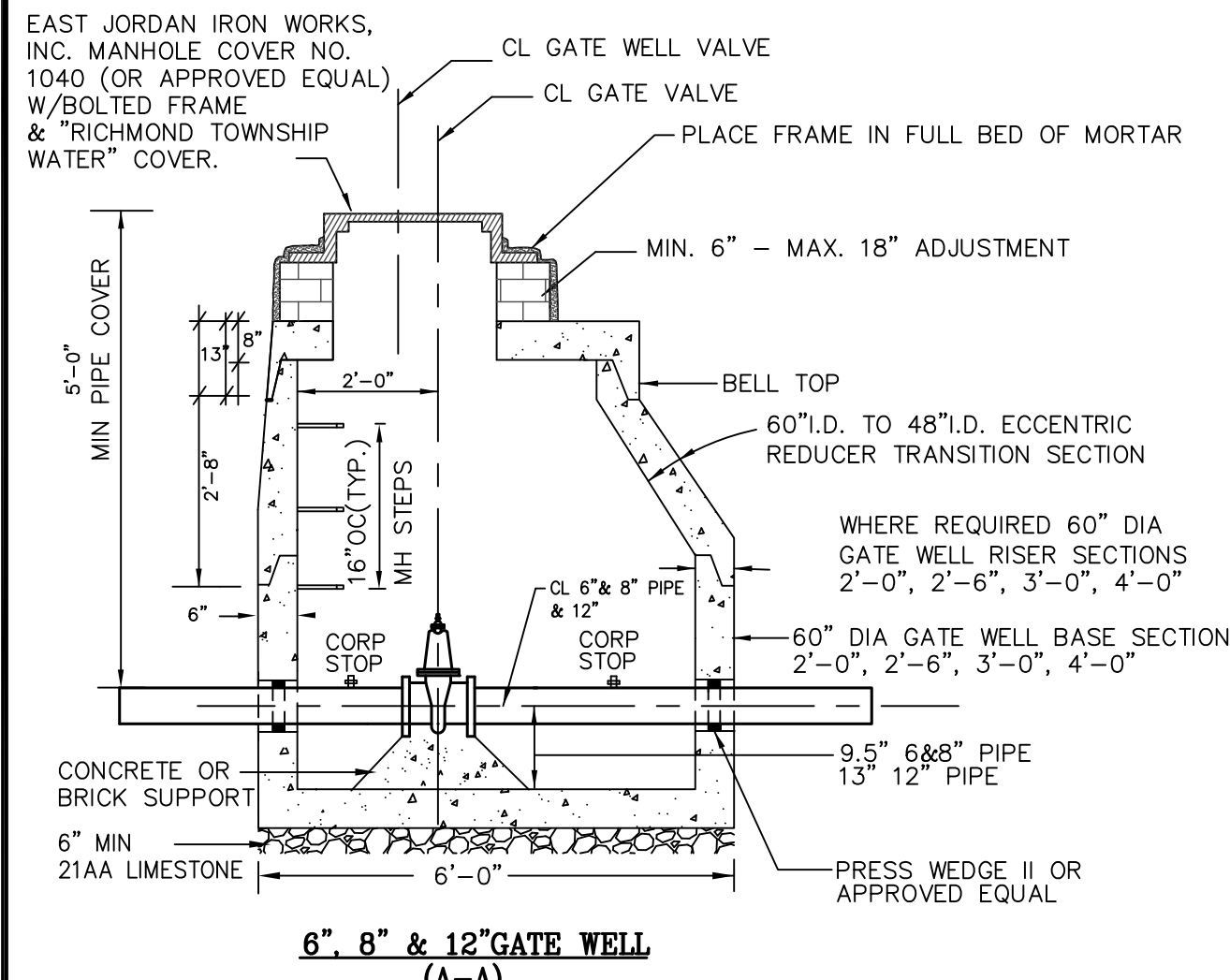

6\"/>

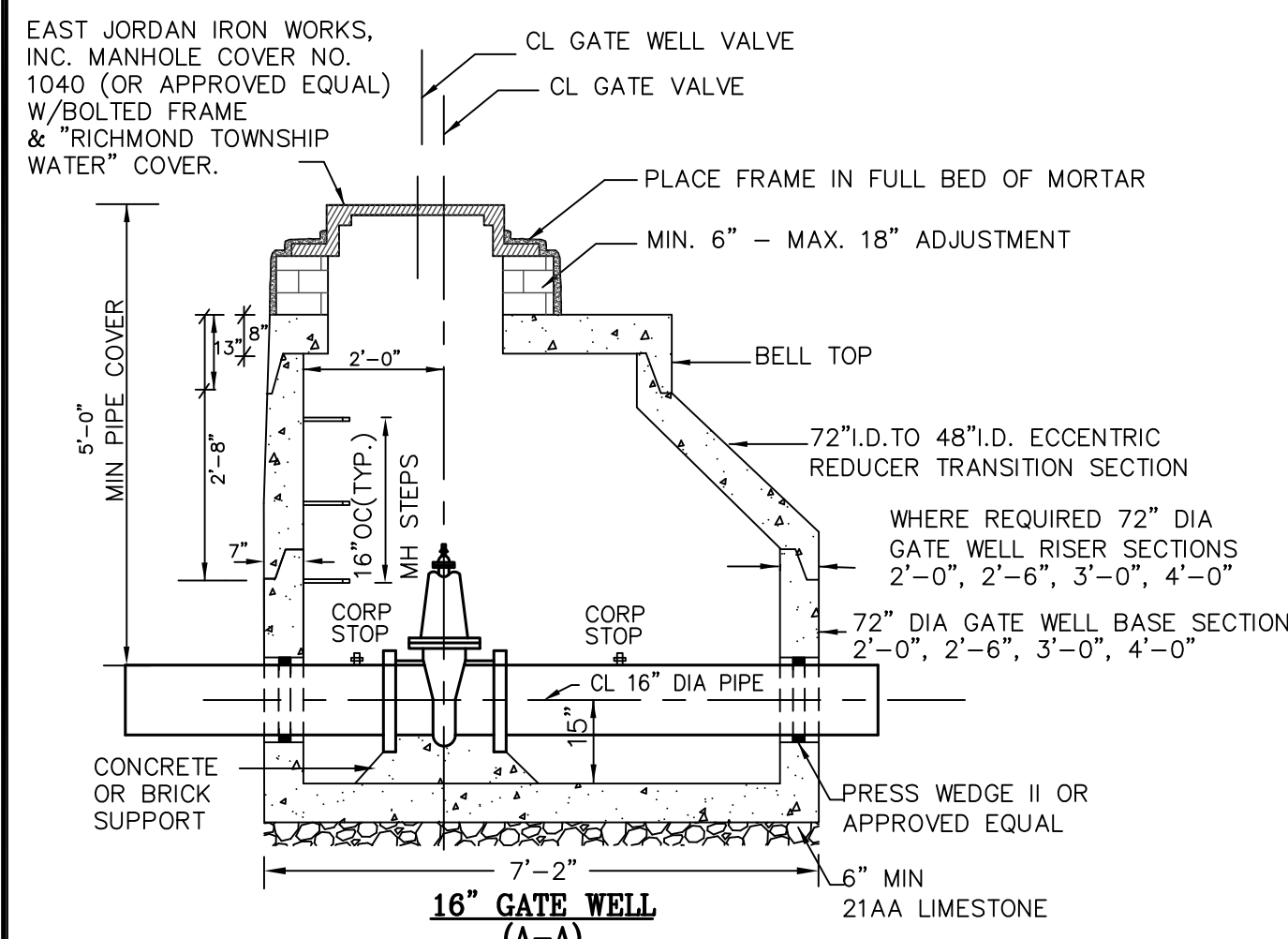

16\"/>

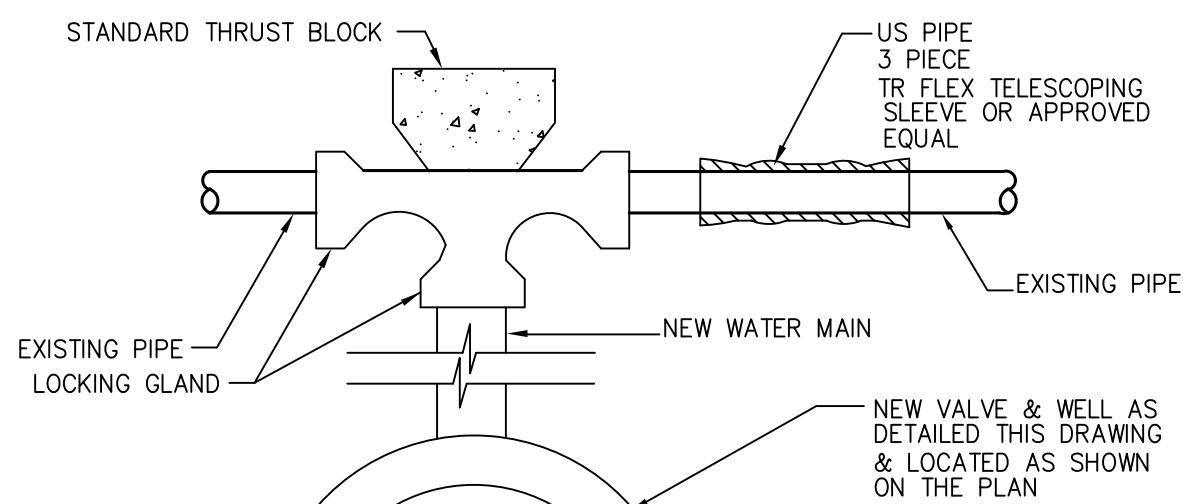

- NOTES:**
1. THE CONTRACTOR SHALL LIMIT THE SHUTDOWN PERIOD OF THE EXISTING MAIN TO THE SHORTEST TIME POSSIBLE BY COMPLETING THE NEW WELL AND DOWNSTREAM PIPING PRIOR TO CUTTING THE NEW TEE. THE CONTRACTOR SHALL OBTAIN A PERMIT FROM THE TOWNSHIP PRIOR TO SHUTTING DOWN THE EXISTING WATER MAIN.
 2. THE CONTRACTOR SHALL HAVE ALL EQUIPMENT AND MATERIALS ON SITE PRIOR TO STARTING WORK ON THE TEE AND SHALL FIELD VERIFY EXISTING PIPE SIZE AND LOCATION OF JOINTS PRIOR TO SHUTTING DOWN THE MAIN.
 3. THE CONTRACTOR WITH THE ASSISTANCE OF THE TOWNSHIP SHALL NOTIFY ALL RESIDENTIAL AND COMMERCIAL CUSTOMERS WITHIN THE SHUTDOWN AREA OF THE ANTICIPATED SHUT DOWN AND THE APPROXIMATE LENGTH OF TIME.

NEW TEE ON EXISTING MAIN

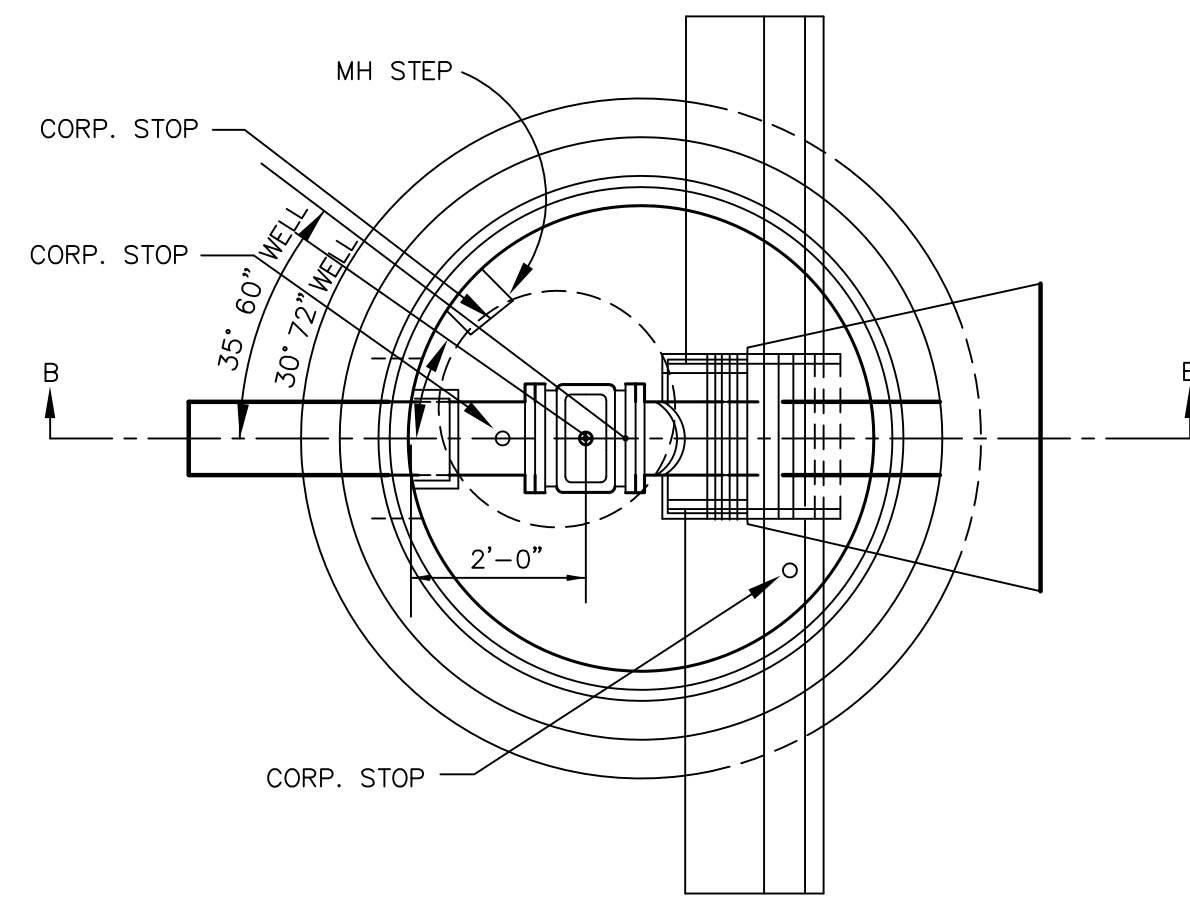

TYPICAL TAPPING SLEEVE VALVE & WELL PLAN

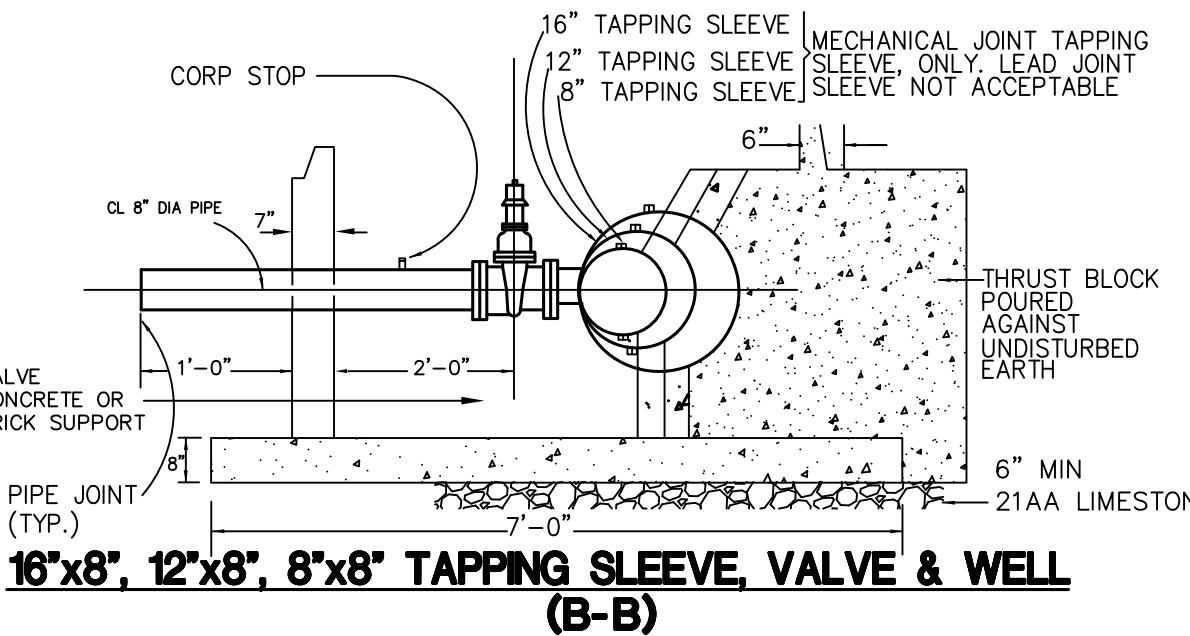

16\"/>

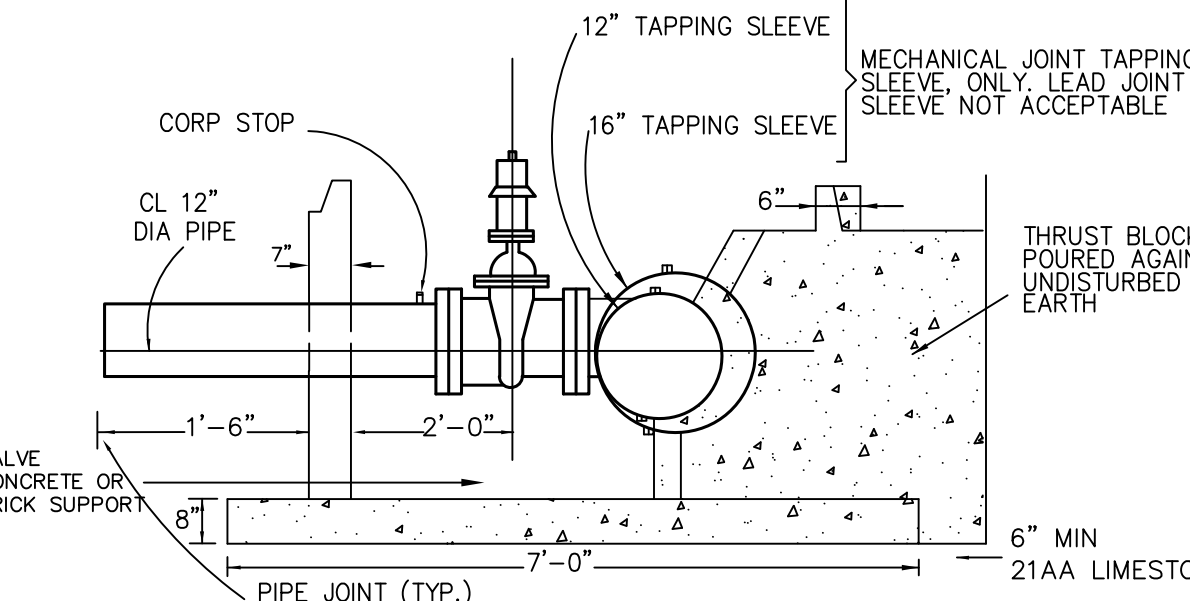

16\"/>

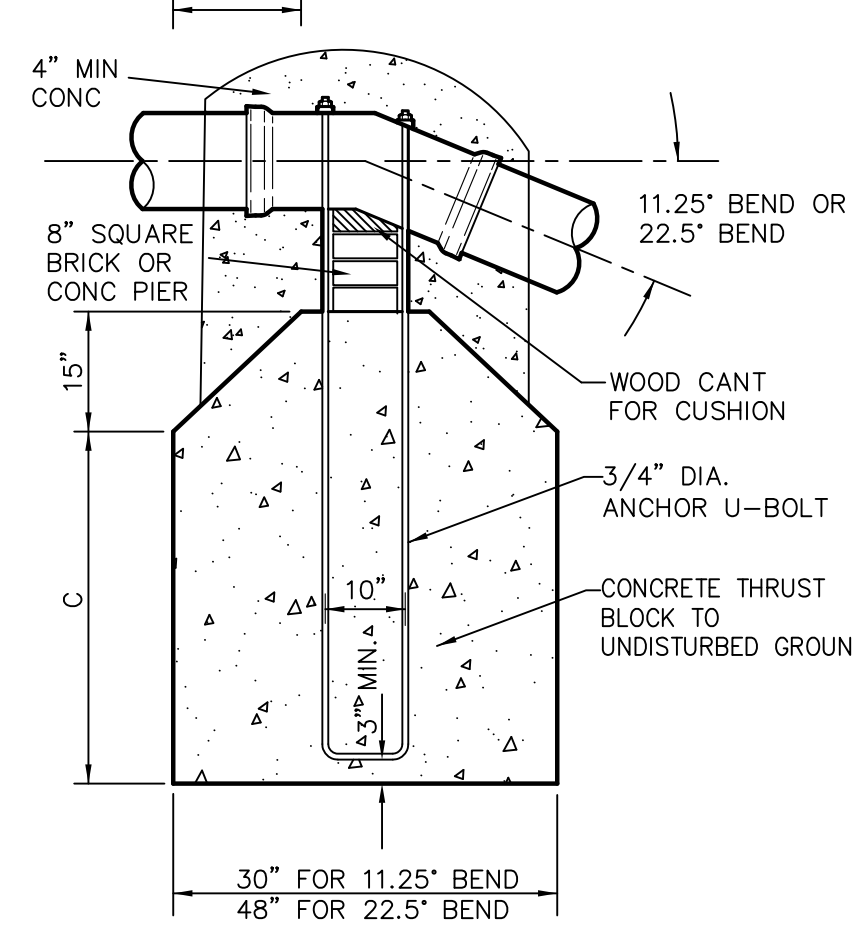
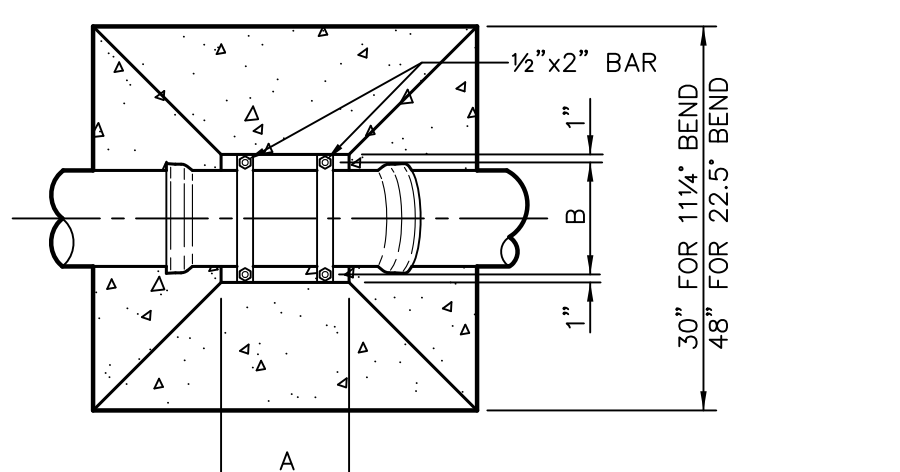

ANCHORAGE SCHEDULE FOR VERTICAL BENDS					
MAIN DIA.	6"	8"	10"	12"	16"
A	1'-0"	1'-0"	1'-2"	1'-4"	1'-9"
B	0'-10"	0'-10"	1'-0"	1'-2"	1'-6"
C	0'-7"	1'-5"	2'-5"	3'-8"	6'-10"

ANCHORAGE FOR VERTICAL BENDS

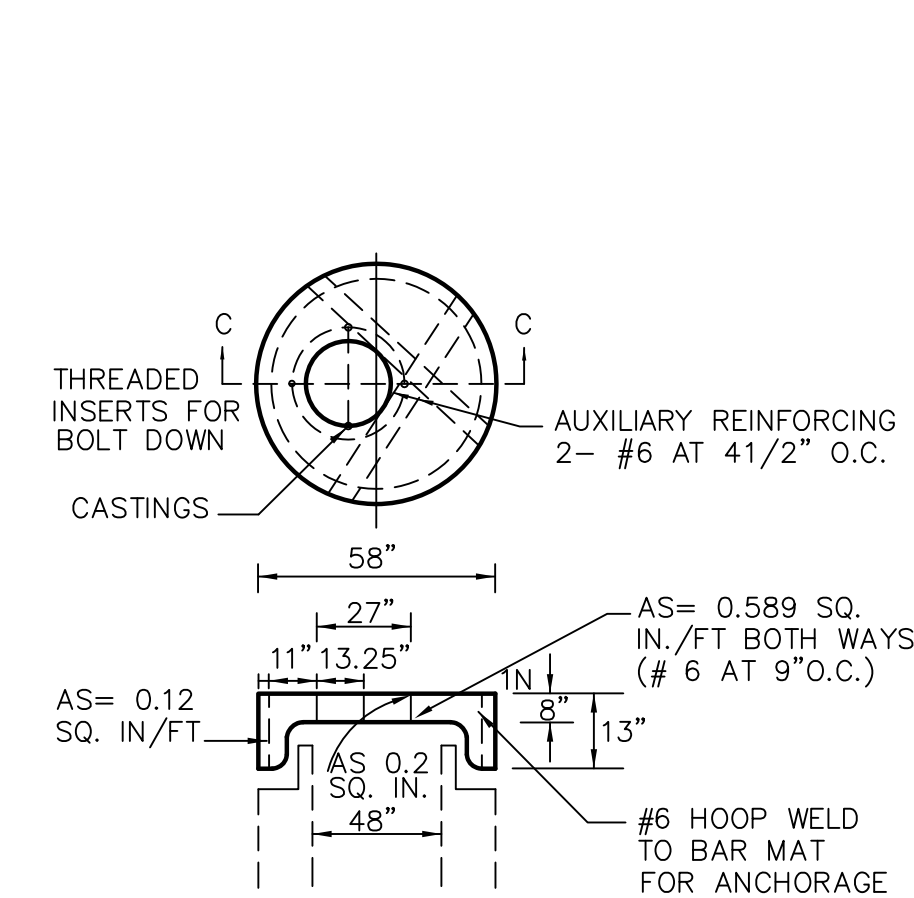

GATE WELL FLAT TOP DETAIL (C-C)

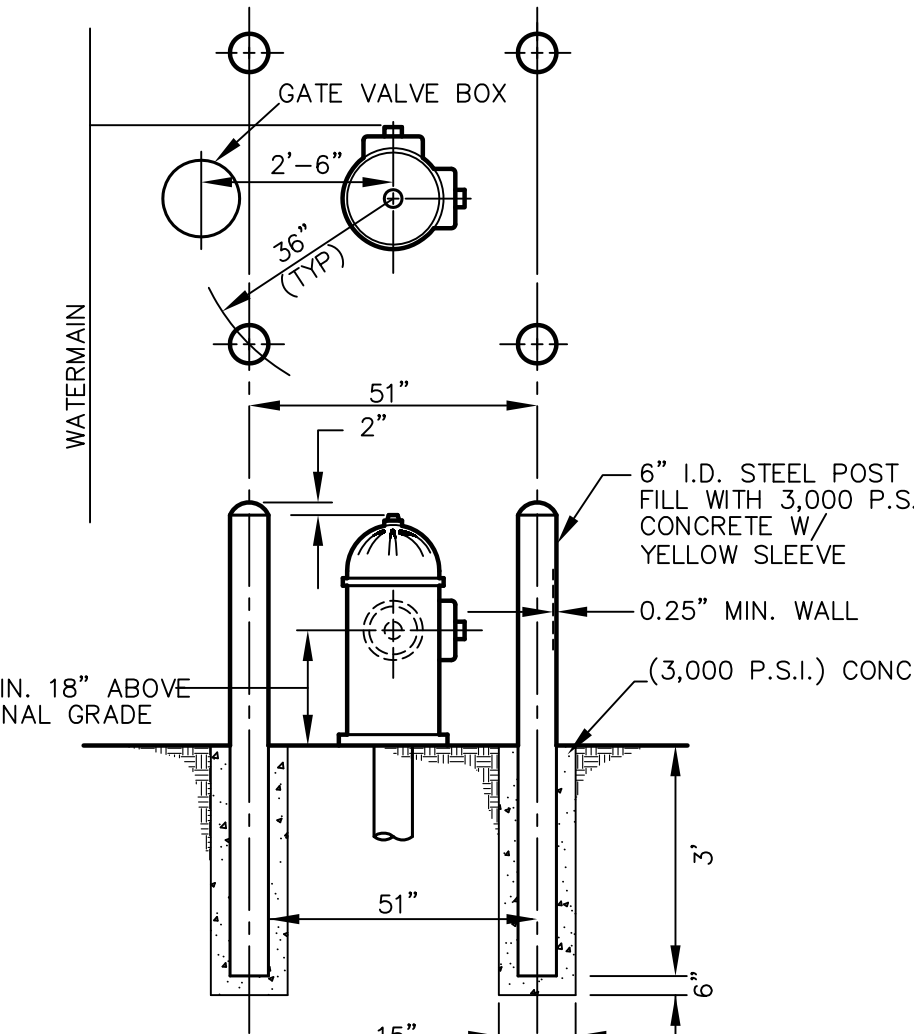

FIRE HYDRANT GUARD POSTS
(AS CALLED FOR ON THE PLANS)

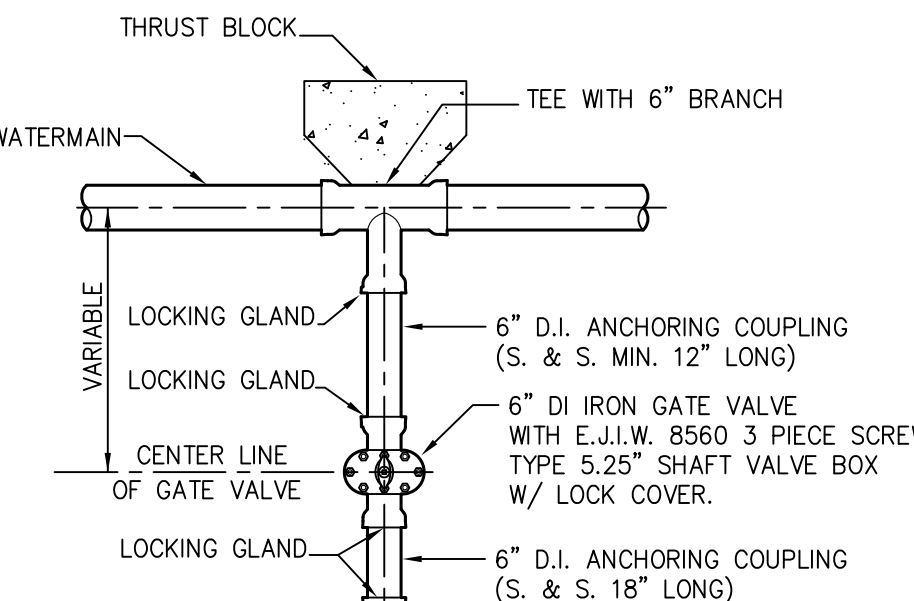

T TYPE CONNECTION
(ONLY W/ DPW APPROVAL)

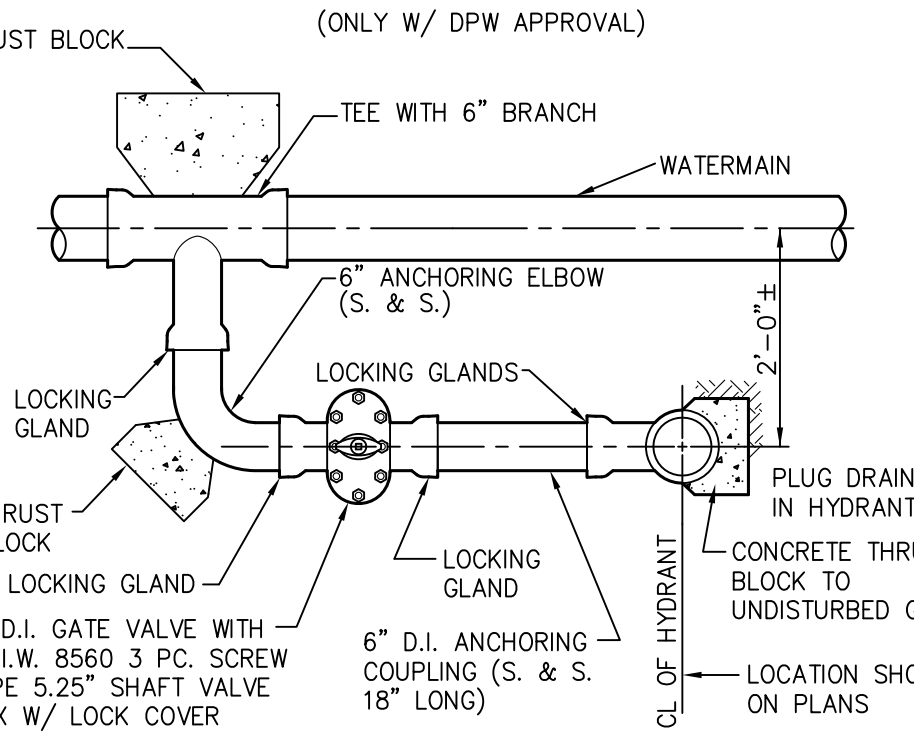

L TYPE CONNECTION

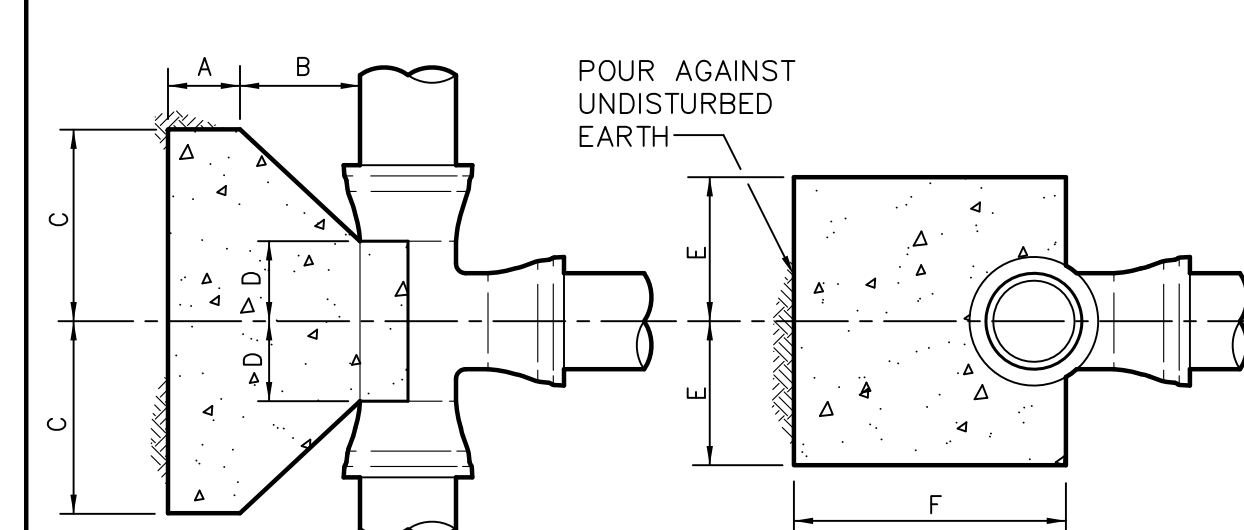

* IN SOFT CLAY DOUBLE THE TABULAR "C" DIMENSION

CONCRETE THRUST BLOCK SCHEDULE FOR TEES							
RUN	BRANCH	A	B	C*	D	E	F
8"	8"	0'-9"	0'-9"	1'-4"	0'-7"	1'-0"	2'-2"
12"	8"	0'-9"	0'-9"	1'-4"	0'-8"	1'-0"	2'-6"
12"	12"	0'-9"	1'-3"	2'-0"	0'-10"	1'-6"	2'-10"
16"	8"	0'-9"	0'-9"	1'-4"	0'-8"	1'-0"	2'-10"
16"	12"	0'-9"	1'-3"	2'-0"	0'-10"	1'-6"	3'-4"
20"	8"	0'-9"	0'-9"	1'-4"	0'-8"	1'-0"	3'-2"
20"	12"	0'-9"	1'-3"	2'-0"	0'-10"	1'-6"	3'-8"
24"	8"	0'-9"	0'-9"	1'-4"	0'-8"	1'-0"	3'-10"
24"	12"	0'-9"	1'-3"	2'-0"	0'-10"	1'-6"	4'-0"
24"	16"	1'-0"	1'-4"	2'-4"	1'-0"	2'-4"	4'-2"
24"	20"	1'-0"	1'-5"	2'-6"	1'-2"	2'-8"	5'-0"
24"	24"	1'-0"	1'-6"	3'-2"	1'-8"	3'-2"	5'-0"

CONCRETE THRUST BLOCK FOR TEES

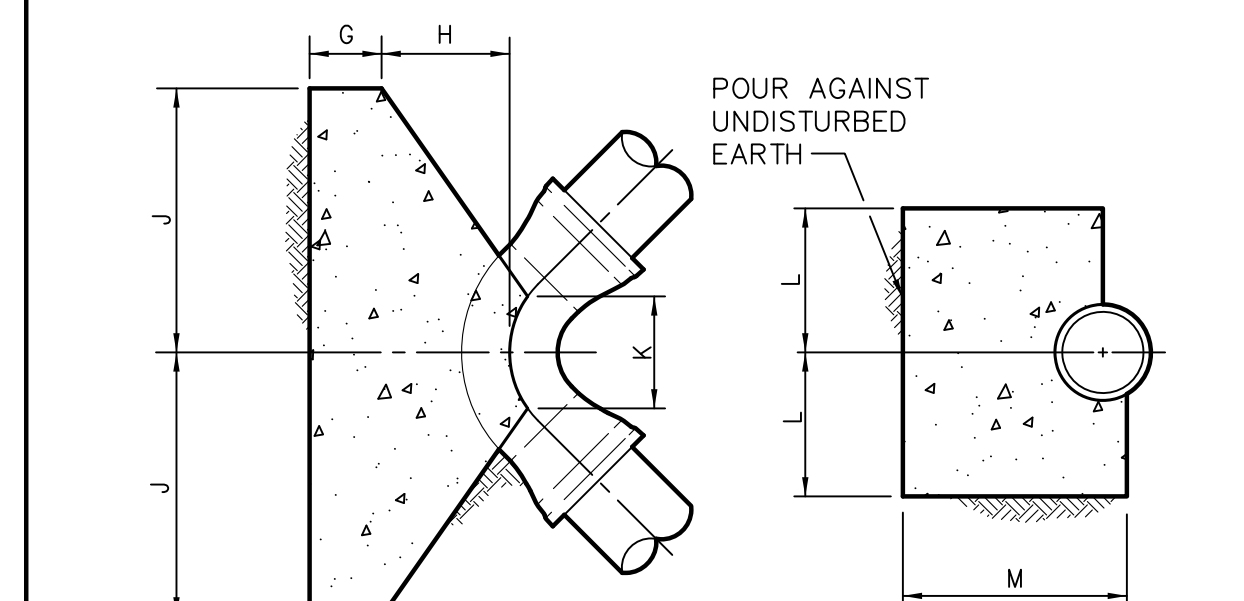

* IN SOFT CLAY DOUBLE THE TABULAR "J" DIMENSION

CONCRETE THRUST BLOCK SCHEDULE FOR HORIZONTAL BENDS							
SIZE	ANGLE	G-MIN.	H	J*	K	L	M-MIN.
6"	45°	0'-9"	0'-9"	0'-9"	0'-6"	0'-9"	1'-8"
	90°	0'-9"	0'-9"	1'-0"	0'-8"	1'-0"	1'-8"
	22.5°	0'-9"	1'-0"	0'-9"	0'-10"	0'-7"	1'-11"
8"	45°	0'-9"	1'-0"	1'-2"	0'-6"	1'-0"	1'-11"
	90°	0'-9"	1'-0"	1'-8"	0'-10"	1'-3"	1'-11"
	22.5°	0'-9"	1'-0"	1'-3"	0'-10"	1'-0"	2'-0"
12"	45°	0'-9"	1'-4"	1'-9"	0'-10"	1'-3"	2'-4"
	90°	0'-9"	1'-4"	2'-9"	1'-2"	1'-6"	2'-4"
	22.5°	1'-0"	1'-8"	1'-8"	0'-10"	1'-3"	3'-0"
16"	45°	1'-0"	1'-8"	2'-8"	0'-10"	1'-6"	3'-0"
	90°	1'-0"	1'-8"	3'-0"	1'-6"	2'-6"	3'-0"
	22.5°	1'-0"	2'-6"	2'-0"	1'-2"	1'-3"	3'-6"
20"	45°	1'-0"	2'-6"	3'-0"	1'-0"	1'-9"	3'-6"
	90°	1'-0"	2'-6"	4'-0"	1'-10"	2'-6"	4'-0"
	22.5°	1'-0"	3'-7"	2'-6"	1'-3"	1'-6"	4'-0"
24"	45°	1'-0"	3'-7"	3'-0"	1'-2"	2'-6"	5'-0"
	90°	1'-0"	3'-7"	5'-0"	2'-2"	3'-6"	5'-4"

CONCRETE THRUST BLOCK FOR BENDS

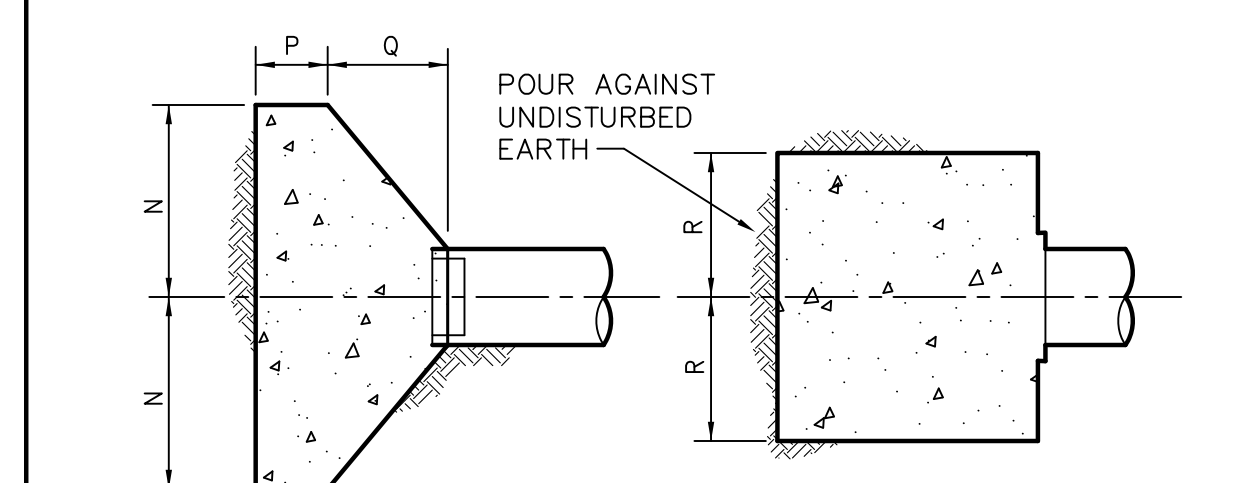

* IN SOFT CLAY DOUBLE THE TABULAR "N" DIMENSION

CONCRETE THRUST BLOCK SCHEDULE FOR PLUGS & CAPS			
SIZE	N*	P-MIN.	R
8"	1'-4"	0'-9"	1'-0"
12"	2'-0"	0'-9"	1'-6"
16"	2'-4"	1'-0"	2'-4"
20"	2'-8"	1'-0"	2'-8"
24"	3'-2"	1'-0"	3'-2"

CONCRETE THRUST BLOCKS FOR PLUGS & CAPS

GENERAL WATERMAIN NOTES

1. THE CONTRACTOR SHALL NOTIFY RICHMOND TOWNSHIP, AND ALL AGENCIES HAVING JURISDICTION (GLWA, EGLE, MDOOT, MCDR, MCOBW), THREE WORKING DAYS PRIOR TO CONSTRUCTION.
2. PRIOR TO CONSTRUCTION, THE CONTRACTOR SHALL ATTEND A PRE-CONSTRUCTION MEETING, AT A TIME AND PLACE AS ARRANGED BY THE TOWNSHIP, IN WHICH VARIOUS UTILITY COMPANIES AND GOVERNMENTAL AGENCY REPRESENTATIVES WILL BE PRESENT.
3. PRIOR TO CONSTRUCTION, THE CONTRACTOR MUST HAVE IN HIS POSSESSION A COPY OF A PERMIT TO CONSTRUCT A CONNECTION TO, OR AN EXTENSION OF, THE TOWNSHIP WATER SUPPLY SYSTEM.
4. PRIOR TO ANY CONSTRUCTION, THE CONTRACTOR SHALL TELEPHONE MISS DIG (800-482-7171) 3 WORKING DAYS BEFORE DIGGING, FOR THE LOCATION OF UNDERGROUND FACILITIES, AND SHALL ALSO NOTIFY REPRESENTATIVES OF ANY OTHER FACILITIES, LOCATED IN THE VICINITY OF THE WORK, WHICH MAY NOT BE HANDLED BY MISS DIG.
5. UNLESS OTHERWISE NOTED, HYDRANTS SHALL BE "L" TYPE AND SHALL BE SET TO THE ELEVATION OF THE EXISTING GROUND. WHEN THE EXISTING GROUND IS HIGHER THAN 0.5 FT ABOVE THE ROAD CENTERLINE, THE HYDRANT SHALL BE EXTENDED UPWARD (FROM 0.5 FT ABOVE THE ROAD CENTERLINE) BY INSERTING BARREL EXTENSIONS BETWEEN THE HEAD AND THE TOP BARREL FLANGE.
6. UNLESS OTHERWISE INDICATED ON THE PLANS, ALL WATER MAIN PIPE SHALL BE ANSI/NSF 61 CERTIFIED & MARKED ON EXTERIOR WALLS, CLASS 54 DUCTILE IRON (CLASS 56 FOR >16") IN ACCORDANCE WITH ANSI/AWWA SPECIFICATION C151/A21.51, DOUBLE THICKNESS CEMENT LINING WITH TYTON PUSH ON JOINTS IN ACCORDANCE WITH AWWA SPECIFICATION C111 AND/OR C115, FITTINGS IN ACCORDANCE WITH AWWA SPECIFICATION C110 AND/OR C153. PLASTIC PIPE MATERIAL (ANSI/NSF 14 CERTIFIED) SHALL ONLY BE USED WITH WRITTEN AUTHORIZATION OF THE TOWNSHIP.
7. UNLESS OTHERWISE INDICATED IN A WATER MAIN PROFILE, WATER MAIN SHALL BE INSTALLED WITH A MINIMUM COVER OF 5 FT AS MEASURED FROM THE PERMANENT PAVEMENT CENTERLINE (OR EXISTING ROAD ELEVATION IF THE PERMANENT PAVEMENT ELEVATION IS NOT KNOWN) ELEVATION OR EXISTING GROUND AT THE WATERMAIN, WHICHEVER RESULTS IN A LOWER ELEVATION. MAX COVER IS 7 FT UNLESS OTHERWISE GRANTED BY THE TOWNSHIP. WHERE THE WATER MAIN CROSSES UNDER OTHER UTILITIES OR DITCHES, A MINIMUM CLEARANCE OF 18" SHALL BE MAINTAINED AND 5 FT UNDER DITCHES. WHERE WATER MAIN MUST DIP UNDER OTHER UTILITIES OR DITCHES, PLACE 22.5" VERTICAL BENDS AND ANCHORAGES ACCORDING TO STANDARD DETAILS.
8. PLACE CONCRETE THRUST BLOCKS FOR ALL BENDS, CAPS, PLUGS OR TEES ACCORDING TO THE STANDARD DETAILS. CONCRETE SHALL HAVE A MINIMUM COMPRESSIVE STRENGTH OF 3,500 PSI AT 28 DAYS. LOCKING GLANDS (MEGA LUGS) SHALL BE PLACED ON ALL BENDS.
9. UNLESS OTHERWISE SHOWN ON THE PLANS, ALL WATER MAIN BEDDING SHALL BE STANDARD BEDDING.
10. ALL END OF LINE GATE WELLS SHALL HAVE STUBS EXTENDING 10 FT FROM THE CENTERLINE OF THE WELL AND ENDING WITH A CAP AND ADEQUATE THRUST BLOCK.
11. UNLESS OTHERWISE INDICATED ON THE PLANS, ALL GATE WELL FRAME & COVERS SHALL BE SET TO THE ELEVATION OF THE EXISTING GROUND OR 0.5 FT ABOVE THE EXISTING ROAD CENTERLINE, WHICHEVER IS HIGHER. COVERS SHALL BE MARKED WITH THE TOWNSHIP STANDARD MARKINGS.
12. ALL WATER MAINS SHALL BE DISINFECTED IN ACCORDANCE WITH CURRENT AWWA STANDARD C651 PRIOR TO PUT IN SERVICE. BACTERIAL SAMPLING SHALL BE IN ACCORDANCE WITH R325.11110 RULES PER MICHIGAN SAFE DRINKING WATER ACT 1976 PA399.
13. AFTER THE WATER MAIN HAS BEEN LAID AND BACKFILLED, EACH SECTION OF THE MAIN, BETWEEN GATE VALVES OR TEST PLUGS/CAPS, SHALL BE HYDROSTATICALLY TESTED FOR LEAKAGE AT A PRESSURE OF 150 PSI. THE FULL PRESSURE SHALL BE MAINTAINED BY PUMPING WATER INTO THE PIPE FOR A PERIOD OF AT LEAST 2 HOURS. THE MAXIMUM PERMISSIBLE LEAKAGE UNDER HYDROSTATIC TEST PRESSURE SHALL NOT EXCEED A RATE OF 0.075 GALLONS PER HOUR PER INCH DIAMETER OF MAIN, PER 1,000 LINEAL FT OF PIPE (AWWA C600-17). NO DIRECT CONNECTIONS ALLOWED UNTIL ALL TESTS COMPLETED AND PASSED.
14. ALL GATE VALVES SHALL BE RESILIENT SEATED IN ACCORDANCE WITH ANSI/AWWA SPECIFICATION C515/A21.51 VALVES WITH STANDARD TURN LEFT TO OPEN.
15. NORMAL INSPECTION WILL BE PROVIDED BY THE TOWNSHIP AT THE CONTRACTOR'S EXPENSE.
16. STRUCTURE STEPS SHALL BE M.A. IND. POLYPROPYLENE PLASTIC W/ #3 DEFORMED BAR (DETAIL P.S.1) SPACED 16" O.C. FROM 24" ABOVE FLOOR TO 16" BELOW TOP OF STRUCTURE.
17. CATHODIC PROTECTION, POLYWRAP 8-MIL THICKNESS PER ANSI/AWWA C105/A21.5, SHALL BE PROVIDED FOR ALL WATER MAIN. ALL BURIED BOLTS, NUTS, AND WASHERS SHALL BE COR-BLUE PER ANSI/AWWA C111/A21.11 OR MUNICIPALITY APPROVED EQUAL.
18. SPECIAL HYDRANT NOTES:
A. ALL HYDRANTS IN RICHMOND TOWNSHIP SHALL HAVE TWO (2) 5" STORTZ W/CAP & CABLE (PUMPER) CONNECTION. THE OPERATING NUT SHALL BE 1.5" PENTAGON, TURN LEFT OPEN.
B. ALL HYDRANTS SHALL BE TRAFFIC MODEL WITH BREAKABLE FLANGE AND COUPLING.
C. ALL HYDRANTS SHALL BE PAINTED WITH TWO (2) COATS OF ENAMEL SAFETY RED (SHERWIN-WILLIAMS INDUSTRIAL & MARINE MERCURY AIR-0-JET B54RF402) AND COLOR CODED TO MEET MUNICIPAL STANDARDS.
D. HYDRANTS SHALL BE EAST JORDAN IRON WORKS MODEL NO. 58R-250 OR DEPARTMENT OF PUBLIC WORKS DETERMINED EQUAL.
E. IF A CULVERT WITH END SECTIONS IS REQUIRED AT THE HYDRANT CONNECTION, THE COST THEREOF WILL BE CONSIDERED INCIDENTAL TO THE HYDRANT CONNECTION, UNLESS CONTAINED IN PROPOSAL AS A BID ITEM.

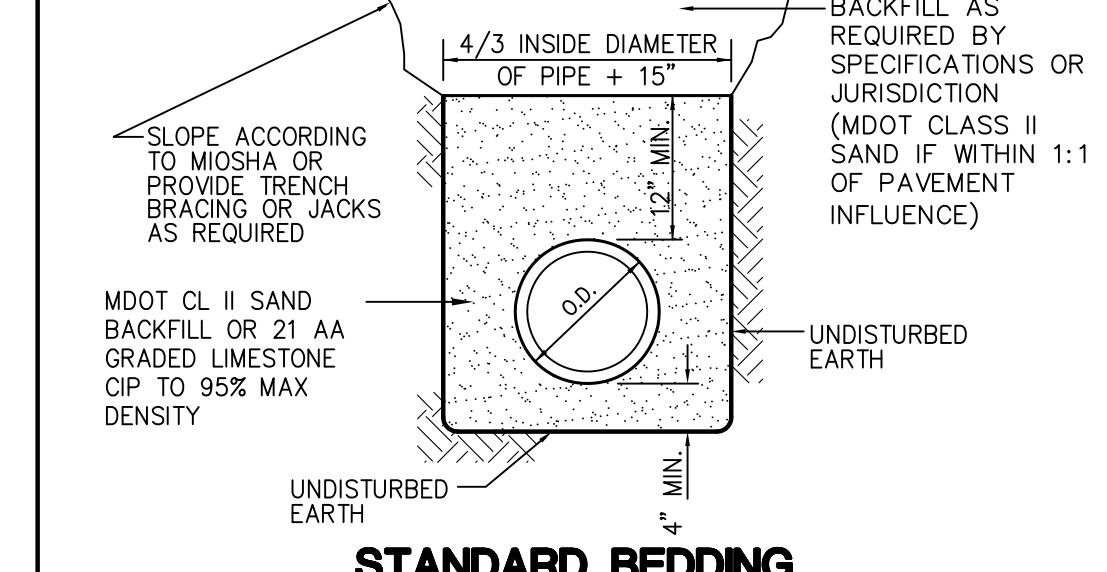

STANDARD BEDDING

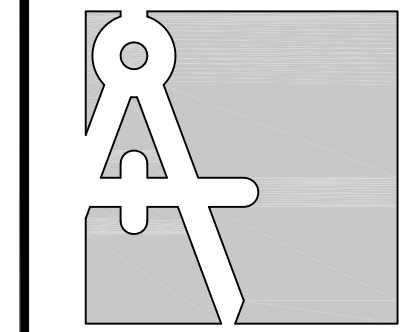

TRI-COUNTY
Engineering Consultants
48701 Hayes Road
Shelby Twp, MI 48315
TEL: (810) 394-7887
FAX: (586) 666-4642
Info@Tri-CountyEng.com
www.Tri-CountyEng.com



CLIENT NAME:
RICHMOND TOWNSHIP
MACOMB COUNTY

3 WORKING DAYS
800-482-7171



Know what's below.
Call before you dig.

PRIOR TO CONSTRUCTION, ALL EXISTING UTILITIES LOCATION AND DEPTH WITHIN THE PROJECT AREA SHALL BE FIELD VERIFIED. CALL MISS DIG SYSTEM 3 WORKING DAYS PRIOR TO CONSTRUCTION.

UTILITY INFORMATION SHOWN ON THIS DRAWING IS APPROXIMATE AND MAY BE ACCORDING TO AVAILABLE RECORD OR DISCLOSED INFORMATION BY VARIOUS UTILITY COMPANIES, PUBLIC AGENCIES, OR OTHER SOURCES AND THIS MAY NOT NECESSARILY REFLECT ACTUAL FIELD LOCATIONS AND NO GUARANTEE IS GIVEN TO COMPLETENESS OR ACCURACY.

COPYRIGHT (C) 2021. ALL RIGHTS RESERVED. THIS DRAWING AND ALL INFORMATION CONTAINED HEREIN ARE NOT TO BE USED, OR REPRODUCED WITHOUT WRITTEN PERMISSION BY TRI-COUNTY ENGINEERING CONSULTANTS.

PROJECT NAME:
RICHMOND TOWNSHIP

WATER MAIN
STANDARD DETAILS

PROJECT LOCATION:
SEC. 105N, R14E
RICHMOND TOWNSHIP
MACOMB COUNTY

Drawn By: TCCE
Checked By: TWP
Approved By: TWP

REVISIONS:
1. 12/17/21

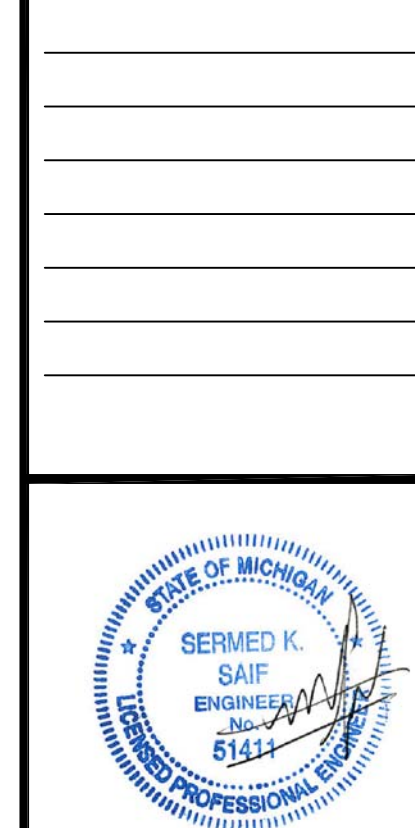

SCALE VERIFICATION:
0 0.5 1
BAR IS ONE-INCH
ADJUST SCALES ACCORDINGLY IF NOT

SCALE:
NONE

DRAWING NO:
RichmondStdWM

Sheet of